

# DESIGNER'S FORUM

## Geotextile-reinforced retaining walls using granular backfills

By Bob Barrett, Al Ruckman and Greg Richardson

**T**HIS COLUMN HAD ITS genesis some 15 years ago at an annual Transportation Research Board (TRB) meeting, when we stirred up the bridge engineers by questioning their qualifications and motives for the cautious approach they were taking to the use of geotextiles as reinforcement in retaining walls. This column will review how we strongly feel that geotextile-reinforced retaining walls should be designed. It emphasizes the simplicity of the design process and the economy and ruggedness of the completed wall. We will limit our approach to applications where good quality granular backfill—i.e., limited fines—is available. Further, we limit the vertical spacing of the geotextile to a uniform 16 in. over the full height of the wall to ensure that a true soil-reinforcement composite is created.

### Historical perspective

The ancient Mesopotamians used soil reinforcement for construction of religious zigurats in the Fertile Crescent. This technology lay dormant for thousands of years until Henri Vidal, while on vacation along the coast of France, discovered that he could build small sand walls by layering pine needles in the sand. This observation quickly led to a series of patents, including patent 3,421,326, issued on Jan. 14, 1969, which protected Vidal's work in the United States. Throughout its 17-year life, this patent was vigorously defended, which limited the understanding and development of earth-reinforced walls by U.S. engineers.

The first reinforced-earth wall was constructed in France in 1966. In 1972, the first U. S. wall of this kind was constructed over a major landslide on U.S. Hwy. 39, in the foothills above Los Angeles. These walls were built with metal strips for their reinforcement and with "select" gravel backfill.

In the mid-1970s, Bob Holtz, under B. Broms at the Swedish Royal Institute of Technology, studied how to use geotextiles to replace steel-reinforcing strips, while the Dick Bell-J.E. Steward team studied the same in the Pacific Northwest. As with the commercial walls of this period, research focused on the use of granular backfill. The

proceedings of the 1978 American Society for Civil Engineers (ASCE) Symposium on Earth Reinforcement provides a good summary of the early years of soil reinforcement (Broms 1978). Unfortunately, many wall designers of the 1990s don't reference work that predates theirs, so this technology's true age may not be appreciated by the novice.

With the expiration of Vidal's patent in 1986, the full commercial potential of soil reinforcement was possible. This ushered in the current era of geogrids and segmental block walls.

### Design basics

The design of soil-reinforced walls traditionally has followed these steps:

1. Evaluate the external stability of the soil-geotextile composite block.
2. Calculate the internal forces acting on the geotextile reinforcement.
3. Design the facing system, including its attachment to the reinforcement.

### External stability considerations

External stability calculations, which date to the late 1960s, model the soil-geotextile composite zone as a rigid block. Four external modes of failure, shown in **Figure 1**, traditionally have been evaluated. Over the past 25 years, we have observed that some

potential modes of failure do not govern design of the reinforced zone. Therefore, our recommendations related to external stability evaluation are as follows:

**Deep failure:** The ability of the subgrade to support the reinforced-soil mass must be verified using conventional geotechnical slope-stability evaluation procedures. This evaluation is highly dependent on the quality of field data and long-term control of drainage conditions. Typically, this analysis can be performed using one of the many excellent PC-computer-based slope-stability programs that can evaluate both deep circular failures within the subgrade and shallow-block failures adjacent to the reinforced soil block.

Reinforced-soil walls are internally stable and do not require embedment. They are content sitting on the ground. Truncated base design also can be used where deep-failure analyses permit. The truncated base design allows the lowermost reinforcement to be a minimum of 3 ft and increases on a 45-degree angle upward to the 0.6 B:H ratio (where B is width of reinforcement and H is height of wall). This was first proposed by Broms (1978).

**Sliding failure:** This models the reinforced zone's ability to hold back the fluid pressures of the soil immediately behind it. This

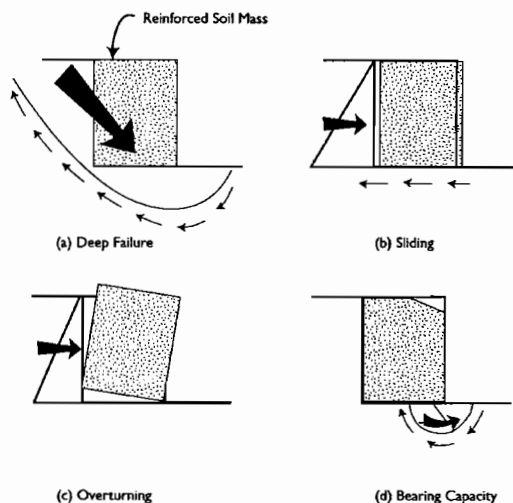

Figure 1. External modes of failure for reinforced-soil structures

## DESIGNER'S FORUM

mode of failure is more properly addressed through deep-failure analyses.

**Overturning failure:** This models the reinforced zone being pushed over (toppled) by the soil pressures acting behind it. Either the rectangle or truncated base design, with a minimum-reinforcement length of 0.6 times the height of the wall in the upper portion, will eliminate this potential.

**Bearing capacity failure:** You still have to support the full weight of the wall facing and composite backfill at the toe of the wall. Do what you must to improve the bearing capacity of the subgrade immediately below the reinforced zone, near the toe of the wall. This doesn't mean that you need great subgrade beneath these walls or that settlements are a major problem if the facing system can tolerate the differential movements. The walls recently constructed by Barrett and Ruckman in the Jamaican swamps demonstrate this assertion (1996).

### Internal stability considerations

By limiting the vertical spacing of the reinforcement, we ensure the development of a composite action with the granular backfill. Larger spacing of the reinforcement necessitates the use of "tie-back" face-panel connections and associated modeling/testing problems.

The internal stability requirement is limited to designing for tension loads within the geotextile and a "pullout" evaluation. The truncated base design is, in fact, based on the pullout evaluation. It is important to understand that the overall factor of safety against rupture of the fabric in these walls typically exceeds 20. A conservative estimate of the interface-friction angle between the geotextile and the backfill soil is  $\frac{1}{2}\phi$ , where  $\phi$  is the internal angle of friction of the soil (Martin et al. 1984).

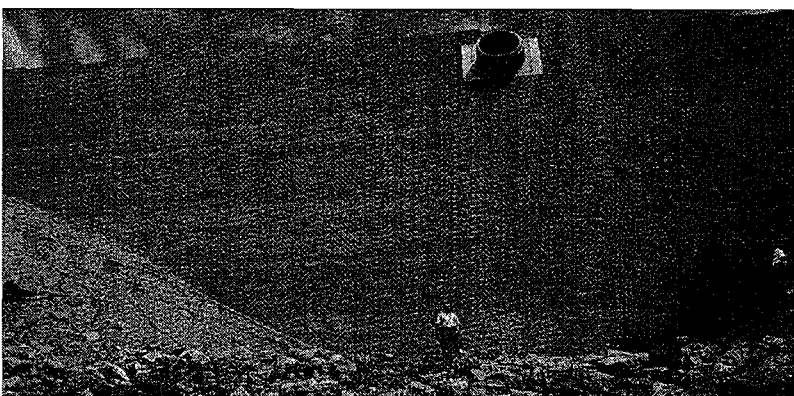

**Photo 1.** This 55-ft.-high wall in Grand Junction, Colo. won an Industrial Fabrics Association International (IFA) 1997 International Achievement Design Award. Its in-place cost was approximately \$14/ft<sup>2</sup>.

Controversy has surrounded the acceptable factor of safety to be used for reducing the ultimate strength of the geotextile to an allowable service strength. These concerns were discussed in an August, 1997, *GFR* article regarding Federal Highway Association (FHWA) degradation-reduction factors for geosynthetics (Elias et al. 1997). For our purposes, the allowable strength of a geotextile is obtained by dividing the ultimate strength of the geotextile,  $T_{ult}$ , by the product of three reduction factors:

$$RF = RF_{CR} RF_{ID} RF_D = \frac{1}{2}$$

where  $RF_{CR}$  is a creep-reduction factor,  $RF_{ID}$  is an installation-damage reduction factor, and  $RF_D$  is a reduction factor for aging. The use of a granular backfill allows us to set both  $RF_{CR}$  and  $RF_D$  equal to one. This type of soil does not creep at these stress levels, and walls constructed with such soils and geotextile have not been observed to strain even 1%. This same granular backfill does not provide "high levels of soluble transition metals ... or an aqueous environment ... under alkaline or high-acidic conditions" (Elias et al. 1997). This means that installation damage,  $RF_{ID}$ , is the sole factor used to calculate the system reduction factor,  $RF$ .

Irresponsible equipment operation—in particular, sharp-turning bulldozers—over a geotextile during installation can significantly damage the material. However, the authors have recovered geosynthetic samples after a minimum of 8 in. of cover was placed and compacted over it. Even with more than 100 passes of a dozer and a loaded dump truck, installation damage to these fabrics was nominal. The 8–16-in. vertical spacings used with the masonry pressed-block segmental faces allow geosynthetic installation with minimal damage.

We recommend the use of an installation

damage reduction factor,  $RF_{ID}$ , of 1.5–2.0 for all geotextiles. Thus,  $RF$  equals 1.5–2.0 ( $K = .4$ ) in our designs. A "K" factor of .4 indirectly addresses deformation. Constructions with granular soils and closely placed geosynthetic reinforcement with ultimate strength reduction of about 60% behave quite stiffly.

This design also assumes the following:

- a minimum of 8 in. of backfill is placed over the geotextile before equipment is allowed on it
- the maximum particle size in the backfill is less than  $\frac{1}{2}$  the layer thickness
- dozers and compactors maintain a minimum 8-in. separation from the fabric and avoid sharp turns.

It is important to understand that good backfill compaction must not be sacrificed to limit geotextile-reinforcement damage. You must correctly compact the backfill and pay attention when the compactor is within 3 ft of the facing to prevent outward movement of the face. The trick is to foot-tamp immediately behind the blocks, then compact the fill, beginning at the facing.

### Cost considerations

A typical 20-ft-tall generic, geotextile-reinforced retaining wall using granular backfill will cost less than \$15/ft<sup>2</sup> of face. The cost commonly breaks down to the following: \$.90–\$6 for the masonry facing, \$1–2 for the reinforcement, \$3–4 for the granular backfill, and \$4–6 for labor. The beauty of the system is the small increase in unit cost with increasing wall height. For the 55-ft-high wall constructed in Grand County, Colo. (see **Photo 1**), the in-place cost was approximately \$14/ft<sup>2</sup>.

## Design procedure

The U.S. Forest Service method (developed in 1977 and revised in 1983) is a conservative and easily understood means of designing soil-reinforced walls. It is based on earlier design methods developed for steel-reinforcing strips by Lee, et al. (1972) and Vidal (1969). It has been shown to greatly over-predict the stresses acting in the reinforcement layers but readily handles unusual load conditions.

### Step 1. Establish wall profile and check design assumptions

Establish the wall profile from the grading plan of the wall site and verify the following design assumptions:

- the wall face is vertical or near vertical
- the backfill is granular and free-draining
- the wall is constructed over a firm foundation or stabilized, improved soils

- the live loads are vertical.

If any of the design assumptions are not satisfied, the design method must be modified.

### Step 2. Determine backfill properties

The friction angle,  $\phi$ , of the backfill soil can be estimated conservatively by a soil engineer or determined by performing appropriate direct shear or triaxial tests. The unit weight,  $\gamma$ , can be determined in a moisture-density test. Generally, the unit weight at 95% Standard Proctor relative compaction (i.e., 95% of American Association of State Highway Transportation Officials T-99 maximum unit weight) is specified. However, other densities also can be specified, as long as the friction angle is consistent with that density.

### Step 3. Develop diagram of lateral-earth pressure due to overburden pressure

The friction angle,  $\phi$ , determined in Step 2 can be used to calculate the coefficient of earth pressure at rest,  $K_0 = 1 - \sin \phi$ , which in turn can be used to establish the linear lateral-earth-pressure diagram along the height of the wall (see Figure 2). The lateral earth pressure at depth  $z$  (measured from the crest) is:

$$\sigma_{h(0)} = K_0 (\gamma z + q)$$

there  $q$  is the vertical-surcharge pressure uniformly applied on the crest.

### Step 4. Develop diagram of lateral-earth pressure due to live loads

The lateral-earth pressure due to live loads can be calculated by Boussinesq equations (published by French mathematician J.V. Boussinesq in 1885). Solutions for line and point loads are presented on Figure 3 (Department of the Navy, 1982) and can be found in most foundation engineering text books. When multiple live loads are applied,  $\sigma_h$  can be obtained by superimposing the pressure due to each live load. An example for calculating lateral-earth pressure due to an eight-wheel, 40-kip, dual-tandem-axle truck can be found in Steward, et al. (1983) and Koerner (1990). Normally, one-three sections along the wall should be checked to determine which is most critical. The ability to easily handle unusual live and dead loads is one of the significant pluses of the Forest Service Method.

### Step 5. Develop composite lateral-earth pressure diagram

The lateral-earth pressure diagrams determined from Steps 3 and 4 are superimposed to form a composite lateral-earth pressure diagram, as shown in Figure 2.

### Step 6. Determine uniform vertical spacing of reinforcement layers

The uniform vertical spacing between reinforcement layers,  $s$ , can be determined by the following equation:

$$s = T_{\text{allowable}} / (\sigma_h)_{\text{max}} * F_s$$

in which  $(\sigma_h)_{\text{max}}$  is the maximum horizontal force from Figure 3, and  $F_s$ , the factor of safety, is at least 1.2–1.5, depending on the confidence level in the ultimate strength of the reinforcement. The vertical spacing of the reinforcement should be less than or equal to 16 in. to ensure development of a composite action between the backfill soil and the geotextile. Note that, by maintain-

ing constant vertical-reinforcement spacing, the design tension will be reduced with decreasing depth of reinforcement. This allows the use of a lesser-strength geotextile at shallow backfill depths.

Creep has been shown to be of little concern in granular soils using this design method. Remember that the stresses predicted by this design method are larger than those measured in the field.

### Step 7. Determine the length of reinforcement required to develop pullout resistance

As shown in Figure 4, the total length of reinforcement,  $L$ , required to prevent pull-

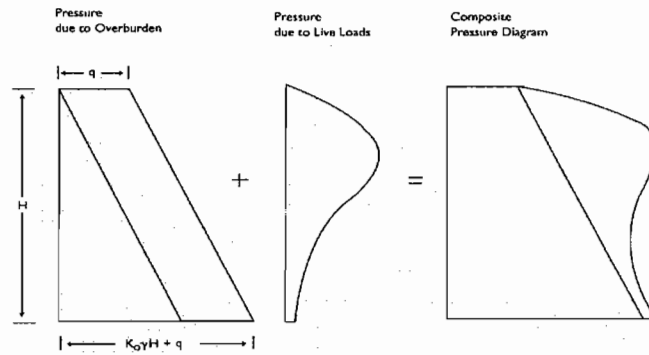

Figure 2. Lateral-earth pressure due to overburden and live loads

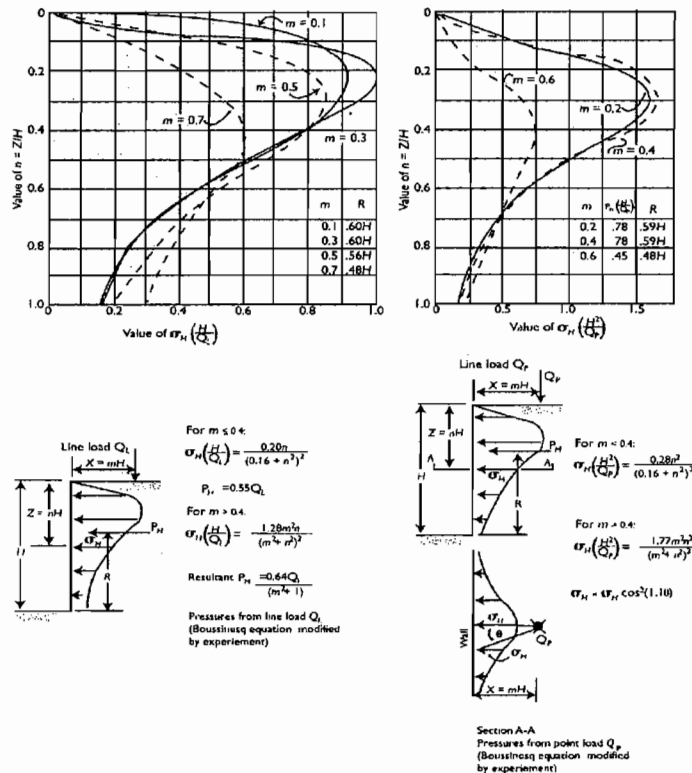

Figure 3. Solutions for line and point loads, USFS design method

## DESIGNER'S FORUM

out failure from occurring is equal to the sum of the anchored length behind the potential failure plane,  $L_e$ , and the length within the potential failure zone,  $L_f$ . For a reinforcement at depth  $z$  below the crest:

$$L = L_e + L_f$$

where  $L_f = (H - z) \tan(45^\circ - \phi/2)$

$$L_e = \frac{K_0 s F_s}{2 \tan(\phi)}$$

where  $H$  is the wall height and  $z$  is the depth of reinforcement layer being considered. The safety factor against pullout failure,  $F_s$ , should be at least 1.5. A minimum value of  $L_e = 3$  ft should be used. The truncated base design allows the reinforcement layers at the base to be shorter than those at the top to sat-

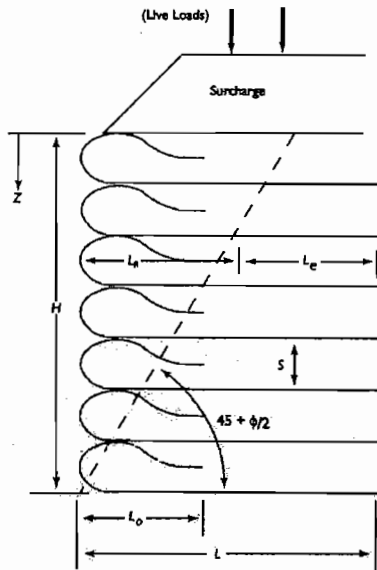

**Figure 4.** Method for determining pullout failure

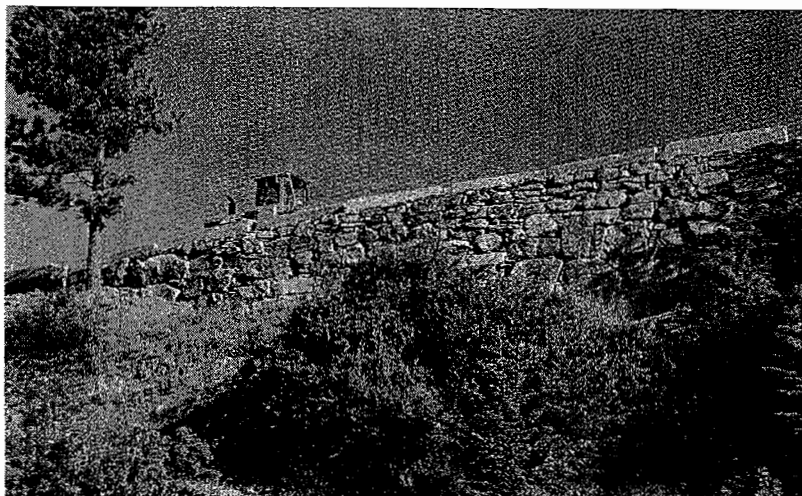

**Photo 2.** A 20-ft. high stone-face wall in Blackhawk, Colo. maintains the connection between the geotextile reinforcement and the stones through simple friction.

isfy the internal stability of the reinforced structure. It is particularly helpful if the width of the working bench is limited. However, reinforcement layers of uniform length are commonly used to factor in external stability considerations (Step 8) and to minimize cutting of the geosynthetic.

### Step 8: Check external stability

The external stability in deep and foundation-bearing capacity-failure modes must be evaluated. Deep failure is best evaluated with a slope-stability computer program such as STABL. The subgrade-bearing capacity is checked using a conventional foundation analysis performed at the toe of the wall (Department of the Navy 1982, Terzaghi and Peck 1968).

### Step 9. Check facing connection

Due to the restricted vertical spacing of the geotextile reinforcement, the lateral forces acting on the face are quite small. For a wrapped geotextile facing, shown in Figure 4, the top embedment length of the geotextile forming the face should be 3 ft. For block or other segmental facing, the connection strength can be calculated as the "bin pressures" or lateral-earth pressure of the soil between the reinforcement layers. Typically these bin pressures are less than 10–15 psf. **Photo 2** shows a 20-ft high stone-faced wall that uses simple friction between the geotextile reinforcement and the stones to maintain the connection.

## Summary

Geotextile-reinforced retaining walls constructed using granular backfill and closely spaced reinforcements are durable, economical and easy to construct. Our recommended design has been successfully

demonstrated in hundreds of walls and bridge supports around the world. Unfortunately, outdated high-strength reinforcement regulations and guidelines continue to hinder this method.

We again want to emphasize that the design method outlined here is not suitable for cohesive backfills. The key points presented in this article related to the design of geotextile-reinforced retaining walls constructed using granular backfill are:

- Connection strengths between the facing blocks and the geotextile reinforcement can be based on localized "bin" pressures that actually develop at the face, and not the larger "equivalent fluid" pressures used to select their reinforcement.
- Standard concrete blocks make an acceptable facing for these walls. These blocks should have a compressive strength of at least 4000 psi to ensure durability. The top two courses of blocks are filled with wet or dry concrete to strengthen the top of the wall.
- Strength-reduction factors for creep and aging are not needed. The backfills are not prone to creep, and there is no aqueous environment to accelerate aging.
- The composite geotextile-soil block can be designed using a truncated base geometry with a minimum 3-ft-wide base, increasing at a 45-degree angle to a 0.6 reinforcement depth-to-wall height ratio.

The continued failure of regulatory bodies to recognize the simplicity and cost-saving potential of geotextile-reinforced retaining walls when granular backfill is available is beyond our comprehension. As with all "Designer's Forums," we encourage the response of designers with differing opinions and real-world data to support them.

Mark Wayne of Tensar, Atlanta, is writing the April *GFR* "Designer's Forum," illustrating the design of reinforced walls and slopes using non-granular backfill and higher strength reinforcements. **GFR**

**Bob Barrett** is a consultant to Yenter Companies, Arvada, Colo. **Al Ruckman** is chief engineer and vice president of Yenter. For more information on their designs, see Yenter's Web site at [www.yenter.com](http://www.yenter.com).

**Gregory N. Richardson, Ph.D., P.E.** is principal of G.N. Richardson and Associates, Raleigh, N.C.

*Editor's Note: Though Barrett's reinforced-soil-wall design method is controversial, he has been involved in the invention, development, instrumentation and construction of more than 100 walls.*

*Barrett, Ruckman and Jan Engwis of Yenter Companies received 1997 IFAI International Design Excellence awards for rock-faced reinforced-soil walls in Colo., as well as for the 55-ft. high Grand County, Colo. wall.*

#### References

- Barrett, B. and A. Ruckman, 1996. Geosynthetics in Jamaica. *GFR*. (14, 5, June/July: pp. 28–31). IFAI: St. Paul, Minn.
- Broms, B.B. 1978. Design of Fabric Retaining Structures. *Symposium on Earth Reinforcement*. ASCE: Pittsburgh.
- Department of the Navy, Naval Facilities Engineering Command. 1982. NAVFAC DM-7.2, *Foundations and Earth Structures*. Naval Facilities Engineering Command: Virginia.
- Elias, V., DiMaggio, J.A. and A. DiMillio. 1997. FHWA Technical Note on the Degradation-Reduction Factors for Geosynthetics. *GFR*. (15, 6, August: 24–27). IFAI: Roseville, Minn.
- Holtz, R.D. and B.B. Broms. 1977. Walls Reinforced by Fabrics—Results of Model Tests in *Proceedings of the International Conference on the Use of Fabrics in Geotechnics* vol. 1. Association Amicale des Ingénieurs: Paris.
- Koerner, R.M. 1990. *Designing with Geosynthetics*. Prentice Hall: Englewood Cliffs, N.J.
- Lee, K.L., Adams, J.D. and J.J. Vagneron. 1972. Reinforced Earth-Retaining Walls. *Journal of the Soil Mechanics and Foundations Division*. ASCE: Pittsburgh. (94, SM4, July, pp. 745-764).
- Martin, J.P., Koerner, R.M. and J.E. Whitty. 1984. Experimental Friction Evaluation of Slippage Between Geomembranes, Geotextiles and Soils in *Proceedings of the International Conference on Geomembranes*. IFAI: St. Paul, Minn.
- Steward, J.E., Williamson, R. and J. Mohney. 1977. Guidelines for Use of Fabrics in Construction and Maintenance of Low-Volume Roads, Chapter 5. *Earth Reinforcement*, USDA, Forest Service: Washington, D.C.
- Terzaghi, K. and R. Peck. 1967. *Soil Mechanics in Engineering Practice*. Second ed. John Wiley & Sons: New York. p. 57.
- Vidal, H. 1969. The Principals of Reinforced Earth. *Highway Research Record, No. 282*. Transportation Research Board: Washington, D.C.