

Comparison of Theoretical and Field Performance
of
Machine Foundations on Ohio River Alluvial Deposits

by

Gregory N. Richardson
Soil & Material Engineers, Inc.
Raleigh, North Carolina

Matthew A. Simpson
Structural Dynamics Research Corporation
Milford, Ohio

Abstract: Forced vibration tests were performed on a rectangular and a octagonal foundation to verify the analytical methods used to predict their dynamic performance. The foundations were embedded at a site having a stratigraphy dominated by Ohio River alluvial deposits consisting of silty clays and clayey silts. Elastic properties of the site were evaluated using both surface and borehole techniques, and with correlation of Standard Penetration Test data. Constant force level frequency sweeps were performed on both foundations in vertical and combined rocking with horizontal modes. The measured compliance values are compared with that predicted using elastic half-space and layered system models.

Introduction

The design of structures and foundations subjected to dynamic loads has only recently evolved from an empirical rule-of-thumb procedure to a more rigorous engineering process that reflects the time dependent nature of the applied loads. Current machine foundation design or analysis currently models the machine foundation system as uncoupled in each principle dynamic mode such that a simple mass-spring-dashpot system can be used to model each unique mode. The spring stiffness and damping values for these modal models are obtained from analytical solutions for various foundation geometries resting on the surface of an elastic halfspace (1,2). The principle limitations for this procedure is the lack of mathematical solutions for all foundation shapes and the difficulty associated with assigning a unique set of elastic properties to sites having significant stratigraphy.

The difficulty associated with the modeling of stratified soil layers has led to the development of more mathematically approximate methods that allow for the variation of soil properties with depth. These methods include both finite element analysis (3,4) and simplified plane strain closed form solutions (5,6) that allow layered soil systems to be modeled. The later was selected for use in this study as a comparison to the elastic halfspace solution.

All analytical methods proposed for evaluation of machine foundations require knowledge of the elastic

properties of the soil subgrade. Two in-situ methods are used to evaluate these properties for the soil profile beneath the test site used in this study. The first technique is based on the measurement of the velocity of surface Rayleigh waves generated in response to the application of a steady-state vertical excitation to the surface of the subgrade. The second technique is the seismic cross-hole method that requires measuring the velocity of impact generated wave forms as the travel between parallel boreholes. The surface Rayleigh method requires more specialized equipment but eliminates the need for boreholes at the proposed site.

Two foundations of different geometries were constructed and tested as part of this study. These two foundations consisted of a rectangular foundation approximately 47 by 96 inches in plan and a octahedral shaped foundation of approximately the same surface area. Both foundations are 36 inches thick and were cast in-place with the surrounding soil acting as the formwork. The as-constructed geometries for the two foundations are shown on Figure 1. The octagonal foundation was analytically treated as a circular foundation of the same surface area. These two foundation geometries are typical of that commonly encountered in actual applications.

Foundation compliance values (displacement/ force) were measured in the principle modes for both foundations using a force generator capable of applying a constant force over a fairly broad frequency range. By measuring displacements on the

A reversible impact hammer rich in shear wave energy is used as the seismic source. Compression waves are determined by reversing the direction of cumulative blows of the hammer such that the shear waves tend to cancel and the compressive wave accumulate. Geophone arrays record the passing waves and enable the time required by the shear or compressive front to move from borehole to borehole. A typical geophone record of wave motions is shown on Figure 3b.

Calculation of wave velocities from the travel times measured above requires use of the distances traveled between boreholes. These distances are obtained by performing a borehole deviation survey that measures the verticality of each borehole using inclinometer techniques.

The shear modulus and Poisson's ratio for a given soil strata can be calculated if the shear wave

velocity, V_s , and the compressive wave velocity, V_p , are known for that layer. The shear modulus of the layer is given as

$$G = \rho V_s \quad \text{Eq. 4}$$

where ρ is the mass density of the soil. Poisson's ratio, ν , can be solved for if V_p is known using the following relationship

$$\nu = \frac{(V_p/V_s)^2 - 2}{2(V_p/V_s)^2 - 2} \quad \text{Eq. 5}$$

If the groundwater is shallow, then the compressive wave velocity of the soil is masked by the compressive wave passing through the pore fluids. This is commonly referred to as the Hydro-P phenomena. For these situations values for Poisson's ratio must be estimated.

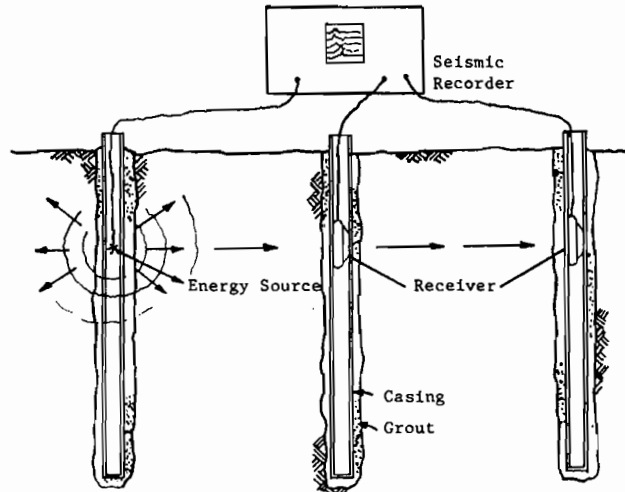

a. Cross-Hole Geometry

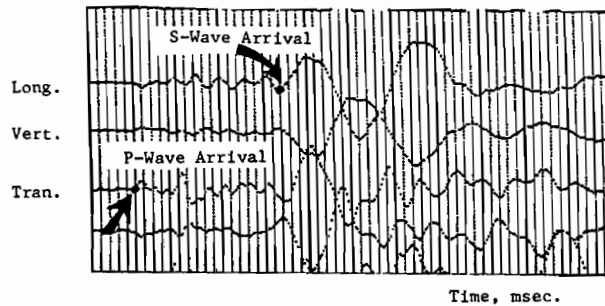

b. Recorded Wave Time-Histories

Figure 3 Cross-Hole Test Geometry and Data

Steady State Vibration Technique

In the steady state vibration technique, a harmonic vertical vibration is applied to the surface of the soil at a given frequency. The length of the wave developed at the ground surface is measured as shown on Figure 4. The velocity of the surface or Rayleigh wave is calculated as the product of the frequency of excitation and the measured wavelength. Because the Rayleigh wave is essentially confined to a surface layer one wavelength in depth, the wave velocity measured on the surface represents some average value of the wave velocity in this zone of soil.

Profiles of Rayleigh wave velocity with depth are obtained by varying the frequency of excitation. Low frequency waves have a long wave length and therefore reflect soil properties to a greater depth than high frequency waves. Rayleigh waves have velocities of 0.935 to 0.95 of the shear wave velocity for the same soil. It is common practice, therefore, to simply treat the measured Rayleigh wave velocity as an equivalent shear wave velocity. The difference is of minor engineering significance.

Comparison of Shear Modulus Values

Profiles of shear modulus with depth as obtained using equations 1 and 3, and from the field tests are presented on Figure 5. While being approximately the same in magnitude, each of the four modulus profiles is unique in shape. With the exception of equation 1, all methods predict an increase in modulus near the ground surface. At depth, the four methods clearly diverge with Equation 1 and the cross-hole data indicating an ever increasing modulus with depth while SPT correlation and the surface excitation data indicate a fairly constant modulus at depth. The benefits obtained from performing the relatively expensive field modulus tests are not discernable from this data.

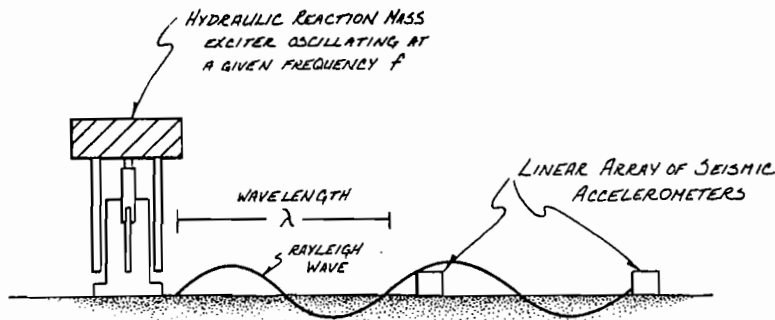

λ IS DETERMINED BY EVALUATING THE PHASE LAG
OF THE SURFACE WAVE AT EACH
ACCELEROMETER LOCATION

V_R IS CALCULATED FROM THE KNOWN f AND THE
MEASURED λ

$$V_R = f \lambda$$

Figure 4 - Measurement of Surface Layer Rayleigh Wave

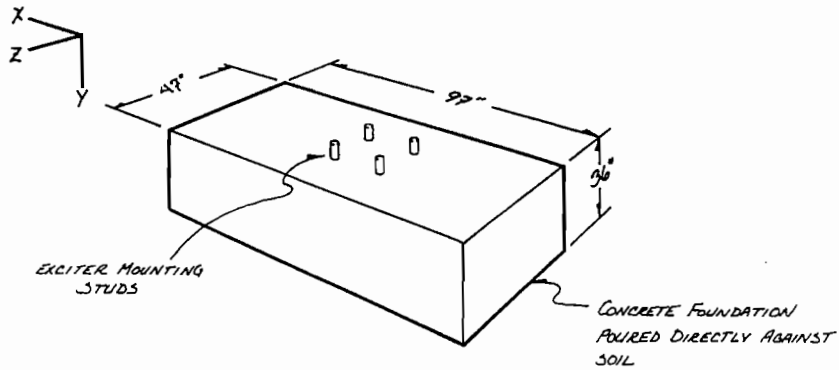

a) Rectangular Foundation

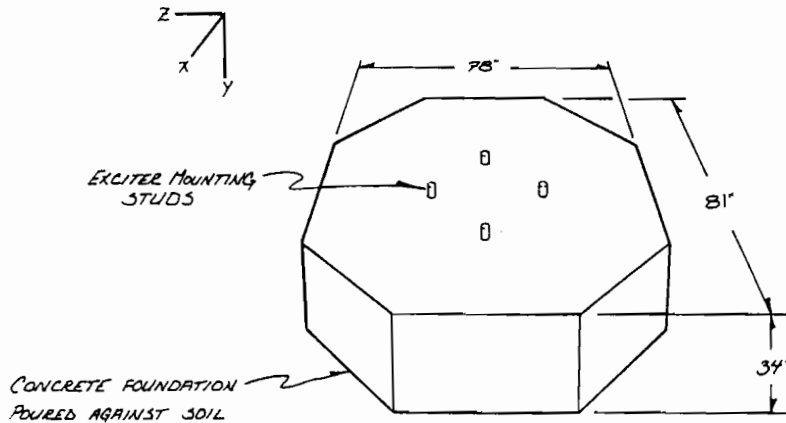

b) Octagonal Foundation

Figure 1 - Foundation Geometries

foundations at discrete frequency intervals, the response spectra for each mode of the foundations was established.

Each foundation was subjected to forced vibration sweeps in their initial embedded condition and after excavation of the soil adjacent to their sidewalls. The influence of foundation embedment is only empirically accounted for using the elastic half-space method whereas the layered system analysis offers the implied advantage of being directly able to account for embedment. The influence of embedment

on the response of machine foundations is a major part of this investigation.

Site Conditions

The test site for this research program is located at the base of a ridge defining the Ohio River Valley. Located 3 miles east of Milford, Ohio, the test site is near the Hillsborough exit of I-275. The site topography is characterized by a gentle slope trending to the northwest and the site has no significant vegetation.

Three borings were made at the test site in preparation for the cross-hole testing and to determine the conventional engineering properties of the subgrade. All borings were made using a rotary drilling technique employing a Bentonite drilling mud to prevent hole collapse. A soil boring log with descriptions of the soils encountered and a graphical representation of the Standard Penetration Test resistances is given on Figure 2. A summary of the engineering properties obtained from these samples is given on Table 1.

The site stratigraphy includes a 3-1/2 foot surface layer of glacially deposited silty clays containing fine sands and some gravel. Beneath the glacial deposits, exist alluvial deposits composed of silty clays and clayey silts. A 5 foot thick seam of coarse sand and gravel is interbedded in the alluvium beginning at a depth of 22 feet.

Subgrade Elastic Properties

Both the elastic half-space and layered system analyses require knowledge of Poisson's ratio and shear modulus values for the soils supporting the foundation. These properties are measured for this study using two techniques that measure the elastic properties of the materials using wave propagation theory. The cross-hole test measures the velocity at which shear and compressive waves move at depth between adjacent boreholes. The surface steady-state vibration technique measures the wave length of a surface Rayleigh wave. Both techniques then utilize elastic wave models to calculate the required elastic properties.

The results of both field tests for shear modulus are compared to empirical relationships obtained from laboratory studies. The shear modulus of an overconsolidated clay is given as (7)

$$G = \frac{1230(2.97-e)^2}{1+e} (OCR)^K \bar{\sigma}_v^{.5} \quad (1b/1n2) \quad Eq. 1$$

where OCR is the overconsolidation ratio for the clay, e is the void ratio, $\bar{\sigma}_v$ is the mean principle effective stress, and K is dependent upon the plasticity of the soil as given in Table 2. In a similar manner, the shear modulus of an angular sand (8) is given as

$$G = \frac{1230(2.97-e)^2}{1+e} \bar{\sigma}_v^{.5} \quad (1b/1n2) \quad Eq. 2$$

where the variables are as defined above. An additional field empirical relationship is presented for comparison. Field seismic shear modulus values are related to Standard Penetration Test (SPT) values using the following expression (9)

$$G = 1550 N^{.8} \quad (1b/1n2) \quad Eq. 3$$

where N is the field SPT blow count.

Cross-Hole Technique

The cross-hole test was performed using techniques conforming to tentative standards prepared by ASTM Committee D18.09. This cross-hole technique uses three adjacent boreholes, a downhole seismic energy source, two downhole geophone arrays, and a multichannel enhancement seismograph to record the generated wave arrivals. The physical arrangement of the cross-hole test is shown on Figure 3a. Note that each borehole is cased and that the annulus between the soil and the casing is grouted.

Table 1 Summary of Subgrade Engineering Properties

Boring No.	Sample No.	Depth (ft.)	Moisture Content (%)	Atterberg Limits			Grain Size Analysis				Specific Gravity	Dry Density (pcf)
				LL (%)	PL (%)	PI (%)	Gravel (%)	Sand (%)	Silt (%)	Clay (%)		
1	1C	0-2	11.3	22.8	14.6	8.2	3	46	43	8	2.76	128.4
	2C	2-4	16.3	26.0	15.1	10.9	5	34	48	13	2.75	119.7
	3C	6-8	19.4	28.4	17.9	10.5	2	16	76	6	2.69	106.2
	4C	10-12	25.6	30.7	20.8	9.9	0	7	87	6	2.73	96.9
	5C	15-17	24.1	28.7	17.1	11.6	0	13	74	13	2.75	99.2
	6C	23-25	17.5	-	-	-	0	17	79	4	2.71	-
2	1	0-1.5	14.2									
	2	2.5-4.0	13.2									
	3	5.0-6.5	20.5									
	4	7.5-9.0	25.0									
	5	10.0-11.5	31.4									
	6	11.5-13.0	29.9									
	7	15.0-16.5	9.8									
	8	20.0-21.5	35.3									
	9	25.0-26.5	28.0									
3	1C	15-17	29.9	29.3	18.1	11.2	1	14	76	9	2.74	103.7
	3C	28-30	14.0	32.0	19.1	12.9	37	26	33	4	2.75	-

Plasticity Index	K
0	0
20	0.18
40	0.30
60	0.41
80	0.48
>100	0.5

SOIL & MATERIAL ENGINEERS, INC.

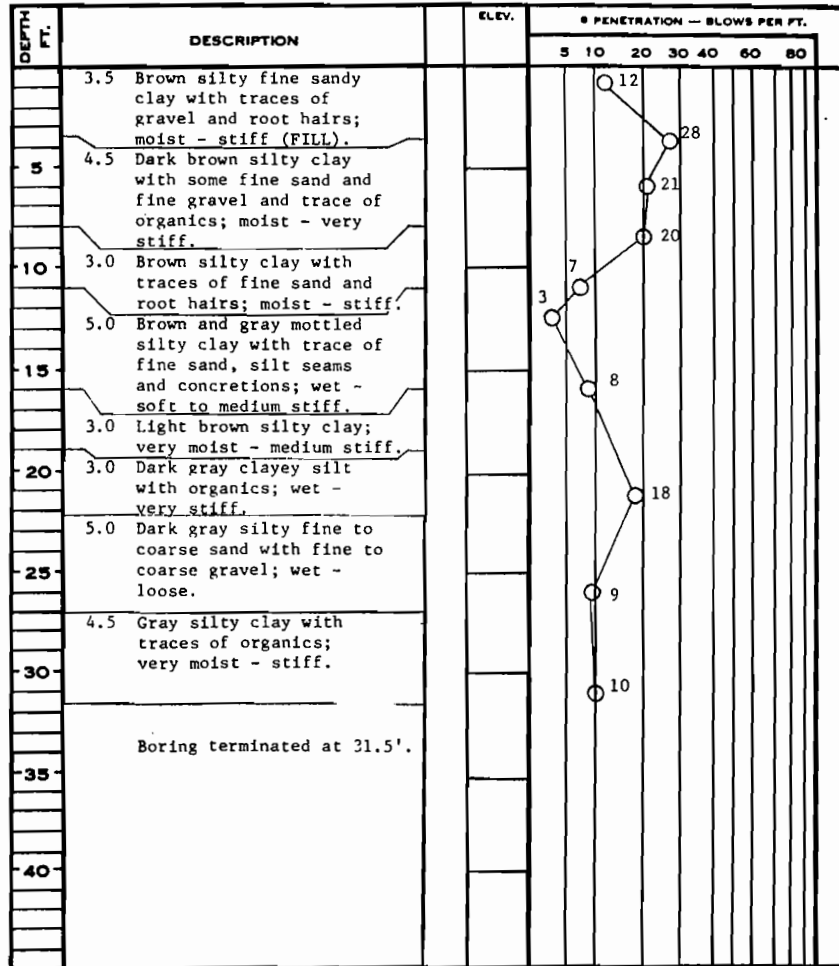

SOIL BORING RECORD

BORING AND SAMPLING MEETS ASTM D-1588
CORE DRILLING MEETS ASTM D-2113

PENETRATION IS THE NUMBER OF BLOWS OF 140 LB. HAMMER
FALLING 30 IN. REQUIRED TO DRIVE 1.4 IN. I. D. SAMPLER 1 FT.

BORING NO. 2
 DATE DRILLED 02-24-82
 JOB NO. 21-82107
 PAGE 1 OF 1

Figure 2 Field Boring Log

Forced Vibration Testing

Forced vibration tests were performed using a closed-loop hydraulic actuator that enabled a constant amplitude of harmonic force to be applied to the foundations over a frequency range of 0 to 98 hertz. The reaction mass hydraulic actuator, or Remass, was fitted with mounting plates such that it could apply a vertical force to the foundation as shown on Figure 6a, or it could apply a horizontal force along either major axis as shown on Figure 6b.

The response of each foundation was monitored using triaxial accelerometer arrays placed at the locations noted on Figure 7. During each test, the frequency of the excitation force was increased from rest to a maximum frequency of 98 hertz. Data was continuously obtained from each accelerometer during each sweep such that the relationships between frequency, force level, and response could be obtained at any arbitrary frequency. This method of testing produces an enormous quantity of data that has been greatly simplified for presentation herein.

Both analytical procedures used in this study attempt to determine the stiffness (force/displacement) relationships of the subgrade using approximate mathematical models. With the possible exception of operational dynamic force levels, the greatest uncertainty associated with the analysis of machine foundations is that related to subgrade stiffness values.

For this study, the field foundation stiffness values were obtained in translational modes by averaging the stiffness values obtained at each corner of the foundation at a frequency sufficiently low that the dynamic amplification factor is one. Rotational stiffness values are obtained using rotations defined by taking the maximum difference between the vertical displacements of opposing ends of the foundation and dividing by the distance between the data points. The static compliance values obtained from forced vibration tests are given in Table 3.

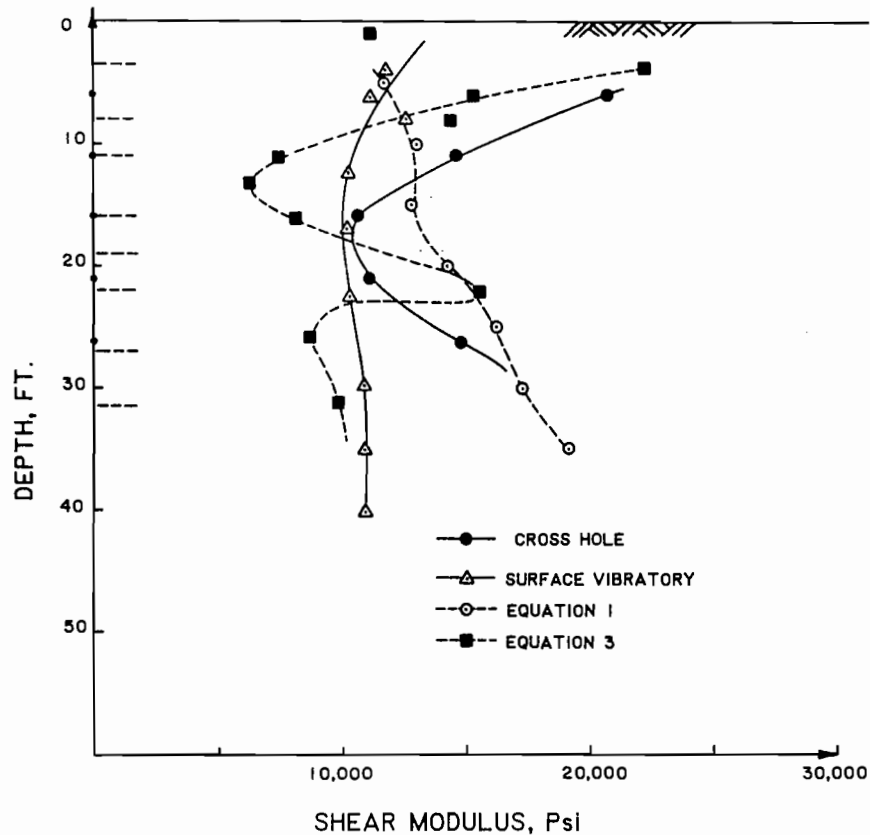

FIGURE 5 MEASURED AND PREDICTED SHEAR MODULUS PROFILES

TABLE 3
Foundation Static Compliance Values
Obtained from Forced Vibration Tests

	Rectangular Foundation		Octagonal Foundation	
	w/Embedment	w/o Embedment	w/Embedment	w/o Embedment
X-Direction Inches/lb.	3.61×10^{-7}	---	8.62×10^{-7}	---
Y-Direction (Vertical) Inches/lb.	3.11×10^{-7}	4.30×10^{-7}	3.26×10^{-7}	4.54×10^{-7}
Z-Direction Inches/lb.	4.11×10^{-7}	2.91×10^{-6}	6.64×10^{-7}	2.25×10^{-6}
About X-Axis Rad/lb.	7.29×10^{-9}	5.54×10^{-8}	1.07×10^{-8}	3.48×10^{-8}
About Z-Axis Rad/lb.	4.17×10^{-9}	---	9.20×10^{-9}	---

Analytical Evaluation

Theoretical foundation compliance values are calculated for each principle mode for the two foundations using conventional elastic half-space models and a more rigorous layered system model. Each theoretical analysis was performed using the shear modulus profiles obtained from the surface vibratory and cross-hole test. Additionally each foundation is analysed for both embedded and non-embedded conditions.

Elastic Half-Space Analysis

Solutions derived from the theory of elasticity model the subgrade as a homogeneous, isotropic, elastic semi-infinite body. The most significant deficiency with this solution technique is the need to assign one unique modulus value to soil profiles that typically have significant variations in modulus with depth. The most practical method to account for such variations in modulus is to use a weighted average of modulus values located one or two foundation diameters below the foundation. Weighing schemes using factors decreasing linearly with depth or inversely with principle deviation stresses have been proposed. For this study, the assumed moduli was obtained using simply the average shear modulus in the upper 15 feet of the soil profile. This resulted in a shear modulus of 17500 psi for the cross-hole profile and a shear modulus of 11000 psi for the surface vibratory profile. A Poisson's ratio of 0.4 is assumed for both modulus profiles.

Formulas for calculating equivalent spring constants based on the elastic half-space solution are presented on Table 4. Equivalent spring constants are calculated using these equations with the average shear modulus values. The resulting stiffness values are converted to compliance values (1/stiffness) and are displayed on Table 5. To be consistent with the measured field data, the rotational compliance values are expressed in terms of force/radian and not moment/radian. This is done by multiplying the conventional compliance value by the moment arm of the applied force about the elastic center of the

foundation. These moment arms are 42 inches and 48.5 inches for the rectangular and octagonal foundations respectively.

Layered System Analysis

Layered system models allow the variation of soil properties to be directly input into the analysis. These properties include the soil unit weight,

Table 4 Equivalent Spring Constants
Elastic Half-Space Analysis

Mode of Vibration	Circular Footing	Rectangular Footing
Vertical	$k_z = \frac{4Gr_o}{1-\nu} n_z$	$k_s = \frac{G}{1-\nu} \beta_z \sqrt{BL} n_z$
Horizontal	$k_s = \frac{32(1-\nu)Gr_o n_x}{7-8\nu}$	$k_s = 2(1+\nu)G\beta_x \sqrt{BL} n_x$
Rocking	$k = \frac{8Gr_o^3}{3(1-\nu)} n_\psi$	$k = \frac{G}{1-\nu} \beta_\psi BL^2 n_\psi$

Note: $\beta_z, \beta_x, \beta_\psi$ defined in reference 1

n_z, n_x, n_ψ defined in reference 2

Poisson's ratio, and damping in addition to shear modulus. The layered system models each soil strata as a plane strain element having a circular inclusion. Deformations between adjacent layers are maintained to be consistent so that the final model acts like a stack of soil layers joined at their boundaries.

Since many machine foundations are not round in shape it is necessary to convert the properties of these foundations into that for an equivalent circular

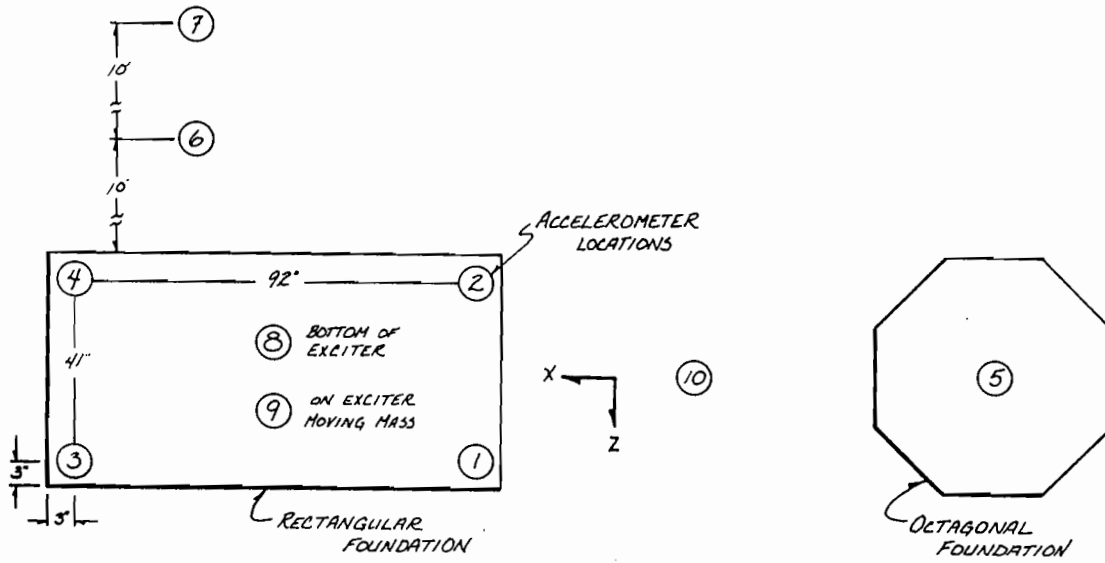

a) Rectangular Foundation Test

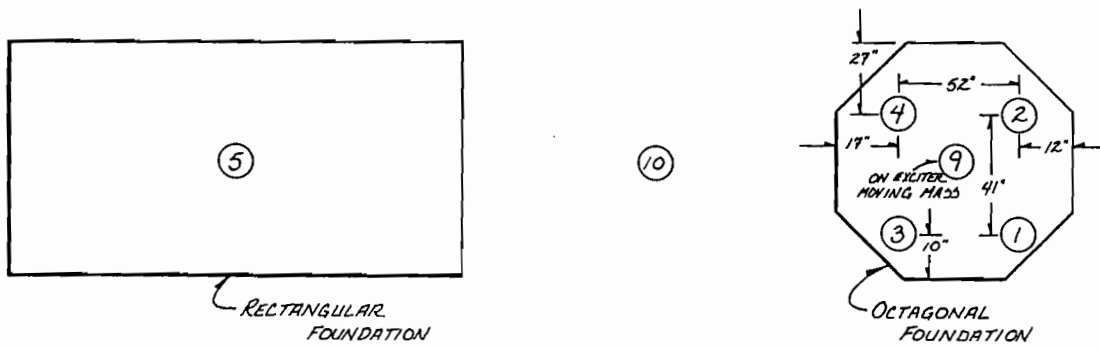

b) Octagonal Foundation Test

Figure 7 - Triaxial Accelerometer Response Locations

foundation. For pure translational modes, this involves using a circular foundation having the same cross sectional area as the noncircular foundation. For pure rotational modes, it is more important that the circular foundation have the same moment of inertia as the true foundation. Combined mode analysis requires approximation of nondiagonal elements in the system stiffness matrix.

The analytically predicted foundation compliance values based on plane-strain layered system analysis are presented on Table 6.

Summary

Field shear modulus values obtained using the cross-hole and surface excitation methods are significantly different in the upper soil layers. Both methods give a poor definition of the shear modulus of the upper 5 feet of soil and yield modulus profiles that converge with increasing depth. Near surface resolution can be improved in the surface technique if higher frequencies of excitation are used. The large vibrator used in this test could be driven to a maximum frequency of 90 hertz so the near surface accuracy was poor. An additional source of discrepancy between the cross-hole and surface excitation test can also be traced to the significant energy imparted to the soil by the Remass. Seed has shown (10) that the shear modulus of clays is significantly reduced by increasing dynamic strain. Thus the larger strains induced into the surface of the subgrade by the Remass would result in the surface test measuring lower shear modulus values than the cross-hole test.

Compliance values predicted using the elastic half-space equations provide a good agreement for the vertical modes and the horizontal stiffness with embedment. The calculated spring constants for the horizontal spring constants without embedment and for rotation with and without embedment are poorly predicted. Since all spring constants are linearly proportional to the shear modulus, and attempt to alter the design modulus value to improve agreement in the horizontal modes would worsen the good agreement achieved in the vertical mode. In all cases the elastic half space equations over estimated the stiffness of rotational and translational spring constants.

Compliance values calculated using the layered system analysis provided good agreement in the translational modes if an equivalent area was used in the analysis. Similarly, the rotational spring constants were in good agreement if the moment of inertia of the model matched that of the actual foundation. The layered system analysis did not provide a good estimate of the rotational stiffness of the embedded rectangular foundation. No reason for this single anomaly was found.

Solutions for foundation compliance values in layered soil systems may be significantly in error using the elastic half-space analysis. It would appear that no single modulus averaging technique will result in good agreement in all modes of vibration using these equations. Layered system techniques provide a good estimate of the subgrade compliance if appropriate properties of the actual foundation are used.

REFERENCES

- 1) Whitman, R.V., and Richart, F.E., Jr., "Design Procedures For Dynamically Loaded Foundations," Journal of the Soil Mechanics and Foundations Division, ASCE, Vol. 43, No. SM6, November 1967.
- 2) Whitman, R.V., "Analysis of Soil Structure Interaction - A State-of-the-Art Review," Soils Publication No. 300, Massachusetts Institute of Technology, April, 1972.
- 3) Kohlemeyer, R.L., "Vertical Vibrations of Footing-Embedded in Layered Media," A Dissertation Submitted in Partial Satisfaction of the Requirements for the Degree of Doctor of Philosophy in Engineering, Univ. of California, Berkeley, Calif., 1969.
- 4) Lysmer, J., and Kohlemeyer, R.L., "Finite Dynamic Model for Infinite Media", J. Eng. Mech. Div., Proc. ASCE, Vol. 95, No. EM4, August, 1969.
- 5) Nogami, T. and Novak, M., "Resistance of Soil to a Horizontally Vibrating Pile," Earthquake Engineering and Structural Dynamics, Vol. 5, 1977.
- 6) Rowe, R. Kerry, and Booker, John R., "Finite Layer Analysis of Nonhomogeneous Soils," Journal of the Engineering Mechanics Division, Vol. 108, No. EM1, February, 1982.
- 7) Hardin, B.O., and Druevich, V.P., "Shear Modulus and Damping in Soils: Design Equations and Curves," Journal of the Soil Mechanics and Foundations Division, ASCE, Vol. 98, No. SM7, 1972.
- 8) Hardin, B.O., and Richart, F.E., Jr., "Elastic Wave Velocities in Granular Soils," Journal of the Soil Mechanics and Foundations Division, ASCE, Vol. 89, No. SM1, February, 1963.
- 9) Ohsaki, Yorhiko, and Iwasaki, Ryoti, "On Dynamic Shear Moduli and Poisson's Ratios of Soil Deposits," Soil and Foundations, Japanese Society of Soil Mechanics and Foundation Engineering, Vol. 13, No. 4., December, 1973.
- 10) Seed, H. Bolton, and Idriss, I.M., "Soil Moduli and Damping Factors for Dynamic Response Analysis," Earthquake Engineering Research Center, Report No. 7070, December, 1970.

Figure 6a
Remass in Vertical
Position

A. Remass in Vertical Position



B. Remass in Horizontal Position

Figure 6 Mounting of Remass to Test Foundations

TABLE 5
Foundation Static Compliance Values
Elastic Half-Space Analysis

	Rectangular Foundation		Octagonal Foundation	
	w/Embedment	w/o Embedment	w/Embedment	w/o Embedment
X-Direction				
Inches/lb.				
Surface	2.60×10^{-7}	4.77×10^{-7}	2.54×10^{-7}	4.42×10^{-7}
Cross-Hole	1.64×10^{-7}	3.00×10^{-7}	1.60×10^{-7}	2.78×10^{-7}
Field	3.61×10^{-7}	---	8.62×10^{-7}	---
Y-Direction (Vertical)	2.78×10^{-7}	3.73×10^{-7}	2.56×10^{-7}	3.34×10^{-7}
	1.75×10^{-7}	2.35×10^{-7}	1.61×10^{-7}	2.10×10^{-7}
	3.10×10^{-7}	4.29×10^{-7}	3.25×10^{-7}	4.54×10^{-7}
Z-Direction	2.60×10^{-7}	4.77×10^{-7}	2.54×10^{-7}	4.42×10^{-7}
	1.64×10^{-7}	3.00×10^{-7}	1.60×10^{-7}	2.78×10^{-7}
	4.11×10^{-7}	2.91×10^{-6}	6.60×10^{-7}	2.25×10^{-6}
About X-Axis				
Rad/lb.				
Surface	2.86×10^{-8}	1.26×10^{-8}	7.09×10^{-9}	1.31×10^{-8}
Cross-Hole	1.80×10^{-8}	7.94×10^{-9}	4.46×10^{-9}	8.25×10^{-9}
Field	7.30×10^{-9}	5.50×10^{-8}	1.07×10^{-8}	---
About Z-Axis	2.52×10^{-8}	4.99×10^{-9}	7.00×10^{-9}	1.31×10^{-8}
	1.59×10^{-8}	3.14×10^{-9}	4.46×10^{-9}	8.25×10^{-9}
	---	---	9.17×10^{-9}	3.48×10^{-8}

TABLE 6
Foundation Static Compliance Values
Layered Soil System Analysis

	Rectangular Foundation		Octagonal Foundation	
	w/Embedment	w/o Embedment	w/Embedment	w/o Embedment
X-Direction				
Inches/lb.				
Surface	8.15×10^{-7}	---	9.05×10^{-7}	---
Cross-Hole	7.15×10^{-7}	---	8.19×10^{-7}	---
Field	3.61×10^{-7}	---	8.62×10^{-7}	---
Y-Direction				
Inches/lb.				
Surface	3.73×10^{-7}	5.20×10^{-7}	4.08×10^{-7}	5.58×10^{-7}
Cross-Hole	2.61×10^{-7}	3.10×10^{-7}	2.84×10^{-7}	3.45×10^{-7}
Field	3.11×10^{-7}	4.30×10^{-7}	3.26×10^{-7}	4.54×10^{-7}
Z-Direction				
Inches/lb.				
Surface	8.15×10^{-7}	2.47×10^{-6}	9.05×10^{-7}	3.02×10^{-6}
Cross-Hole	7.15×10^{-7}	1.34×10^{-6}	8.19×10^{-7}	1.67×10^{-6}
Field	4.11×10^{-7}	2.91×10^{-6}	6.64×10^{-7}	2.25×10^{-6}
About X-Axis				
Rad/lb.				
Surface	1.76×10^{-8}	5.93×10^{-8}	1.46×10^{-8}	4.63×10^{-8}
Cross-Hole	1.58×10^{-8}	3.27×10^{-8}	1.29×10^{-8}	2.58×10^{-8}
Field	7.29×10^{-9}	5.54×10^{-8}	1.07×10^{-8}	3.48×10^{-8}
About Z-Axis				
Rad/lb.				
Surface	7.59×10^{-9}	---	1.46×10^{-8}	---
Cross-Hole	5.84×10^{-9}	---	1.29×10^{-8}	---
Field	4.17×10^{-9}	---	9.20×10^{-9}	---